

SOUTHERN *CRANES & ACCESS*

SOUTHERN *CONTRACT LIFTING*



Z45/25RT
Z45/25J RT

ROUGH TERRAIN
SELF PROPELLED
ARTICULATED BOOM



WEST SUSSEX DEPOT

TEL: 01798 875988

FAX: 01798 875989

sales@southerncranes.co.uk

www.southerncranes.co.uk

LONDON DEPOT

TEL: 0208 6831188

FAX: 0208 683 1199

southernlifting@tiscali.co.uk

STANDARD FEATURES

- 15.9m working height
- Horizontal reach of at least 7.5m
- Up and over clearance of 6.9m
- 1.37m turning radius
- 45 second lift speed to full height
- 227kg lift capacity
- Oscillating axle on 4x4 models
- Dual fuel (Petrol/LPG) or diesel engine option
- Fully proportional controls
- Hydraulic Platform rotation
- 12V DC auxiliary power unit
- Drive enable system
- End mount platform on Z-45/25J models
- AC wiring to platform
- Tilt alarm
- Horn
- Hour meter
- Rough terrain tyres
- Fully certified load sensor

OPTIONS AND ACCESSORIES

- Two or four-wheel drive
- Oscillating or non-oscillating axle on 4x2 models
- Alarm package with beacon
- Cold start packages
- 2500 (50Hz) or 3000 (60Hz) watt AC generator
- Platform swing gate
- Tri-entry platform
- Air line to platform
- Full rail platform pinch guard
- Platform work light
- Platform control box cover
- Hostile environment package
- GS/LPS rating for Ford engine-powered machines
- Foam filled, non-marking and floatation tyre packages
- Half-mesh platform
- Pipe cradle

STANDARDS COMPLIANCE

- CE EN280

RANGE OF MOTION

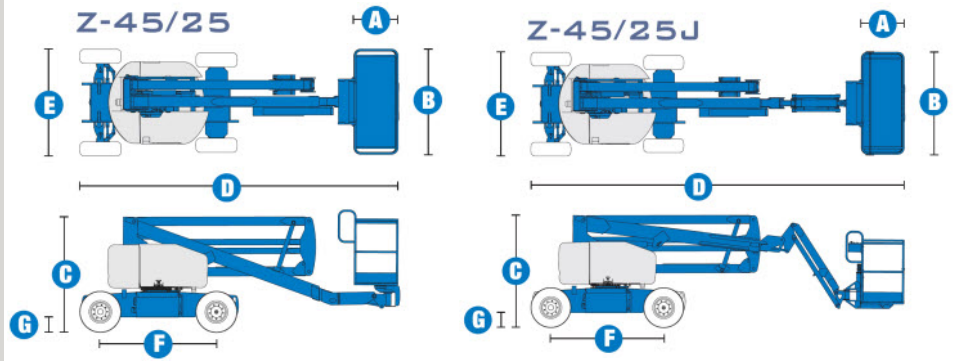
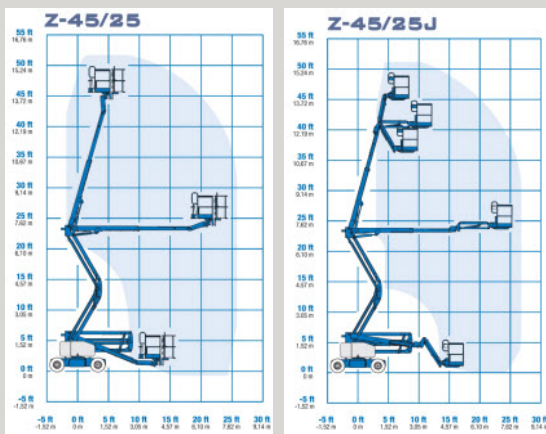

SPECIFICATIONS

Model	Z-45/25	Z-45/25J
Working height*	15.9m	15.9m
Platform height	13.9m	13.9m
Height - stowed (A)	2.08m	2.08m
Length - stowed (B)	5.5m	6.8m
Width (C)	2.24m	2.24m
Wheelbase (D)	2.03m	2.03m
Ground clearance - centre	33cm	33cm
Ground clearance - min (E)	25cm	25cm
Platform length (F)	76cm	76cm
Platform width	1.83m	1.83m
Horizontal reach max	7.5m	7.7m
Up and over clearance	6.9m	6.9m
Lift capacity	227kg	227kg
Turning radius - inside	1.37m	1.37m
Turntable rotation	359° non-continuous	359° non-continuous
Turntable tail-swing	zero	zero
Platform rotation	180°	160°
Power source	Ford LRG 425 Petrol/LPG 82 hp (61kw) Deutz Diesel F3L 1011 36hp (27kw) Perkins Diesel 104-22 50hp (37kw)	
Drive speed - stowed	7.7km/h	7.7km/h
Drive speed - stowed	1km/h	1km/h
Lift speed to full height	45sec	45sec
Controls	12V DC proportional	12V DC proportional
Auxiliary power unit	12V DC	12V DC
Tyres	14-17.5	14-17.5
Gradeability - 4x4	45%	45%
Gradeability - 4x2	30%	30%
Hydraulic tank capacity	95litre	95litre
Fuel tank capacity	54litre	54litre
Weight - 4x4**	6,261kg	6,352kg
Weight - 4x2**	6,171kg	6,261kg

* The equivalent of working height adds 2 m to platform height.

** Weight will vary depending on options and/or country standards