

SOUTHERN CRANES & ACCESS

Genie Z51/30



Southern Cranes & Access Ltd

Pollards Way, Southwater, Horsham, RH13 9AQ

Access hire: 01403 339105 . Crane hire: 01403 790874
sales@southerncranes.co.uk . www.southerncranes.co.uk

Cranes
Access
Transport
Contract Lifting
Training

Genie Z51

Measurements

Working height maximum*	17.62 m
Platform height maximum	15.62 m
Horizontal reach maximum	9.25 m
Up-and-over clearance (max)	7.42 m
A Platform length	0.76 m
B Platform width	1.83 m
C Height - stowed	2.16 m
D Length - stowed	7.50 m
E Width	2.29 m
F Wheelbase	2.03 m
G Ground clearance - centre	0.39 m

Productivity

Lift capacity	227 kg
Platform rotation	160°
Vertical jib rotation	135° (+78°/-57°)
Turntable rotation	355° non-continuous
Turntable tail-swing	zero
Drive speed - stowed	5 mph
Drive speed - raised**	30 cm/s
Gradeability - 4WD stowed***	45%
Turning radius - inside	1.70 m
Turning radius - outside	4.50 m
Controls	12 V DC proportional
Tyres	355/55 D625 foam filled

Power

Power source: Deutz D2011 L03i 3 cylinder diesel 48 hp (35.8 kW)	
Auxiliary power unit	12 V DC
Hydraulic tank capacity	90.9 l
Fuel tank capacity	64.4 l

Sound & Vibration Levels

Sound pressure level	
ground workstation	86 dBA
platform workstation	79 dBA
Vibration	<2.5 m/s ²

Weight****7,212 kg

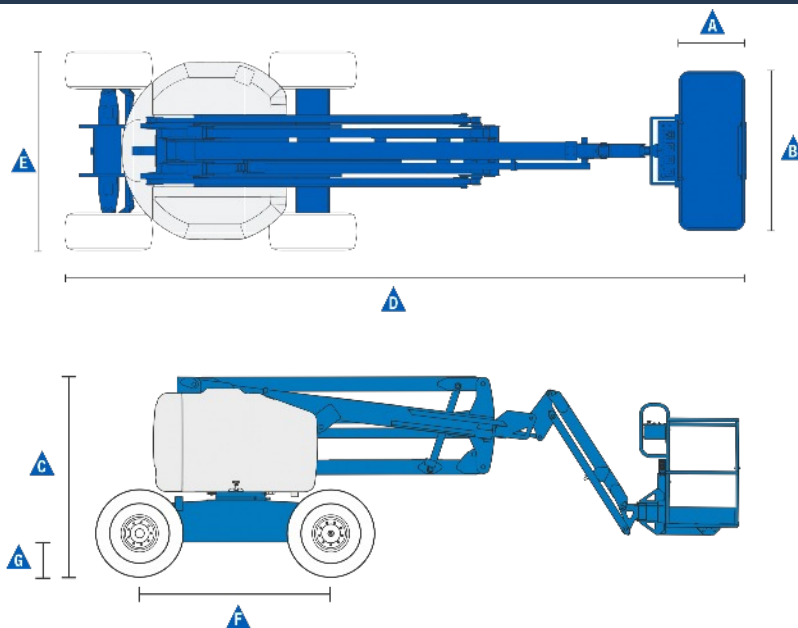

Range of motion

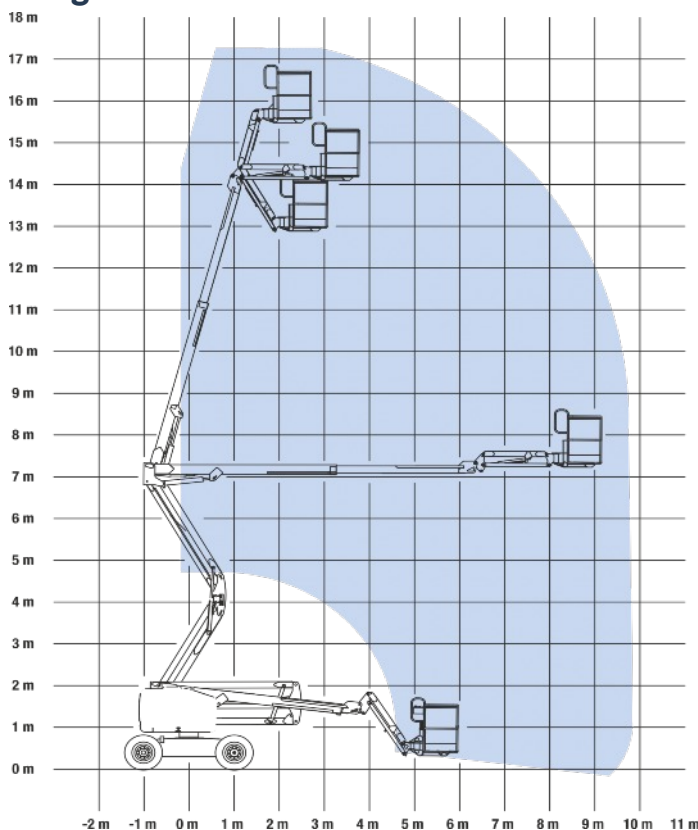

* The metric equivalent of working height adds 2 m to platform height.

**In lift mode (platform raised), the machine is designed to operate on firm, level surfaces only.

***Gradeability applies to driving on slopes. See operator's manual for details regarding slope ratings.

****Weight will vary depending on options and/or country standards.

Southern Cranes & Access Ltd

Pollards Way, Southwater, Horsham, RH13 9AQ

Access hire: 01403 339105 . Crane hire: 01403 790874
sales@southerncranes.co.uk . www.southerncranes.co.uk

14 September 2016