

SOUTHERN CRANES & ACCESS

Liebherr MK140



Southern Cranes & Access Ltd

Pollards Way, Southwater, Horsham, RH13 9AQ

Access hire: 01403 339105 . Crane hire: 01403 790874
sales@southerncranes.co.uk . www.southerncranes.co.uk

Cranes
Access
Transport
Contract Lifting
Training

Liebherr MK140

Trolley mode

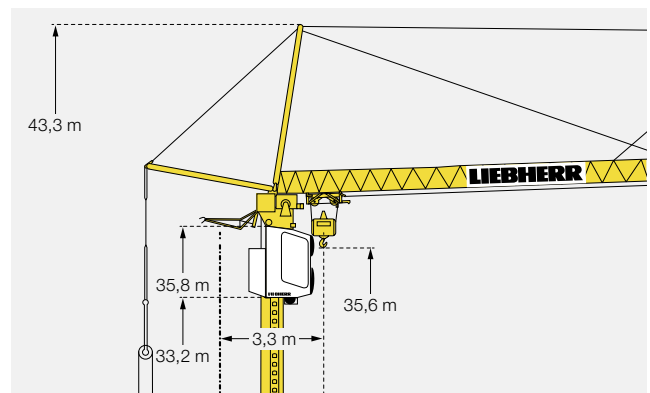
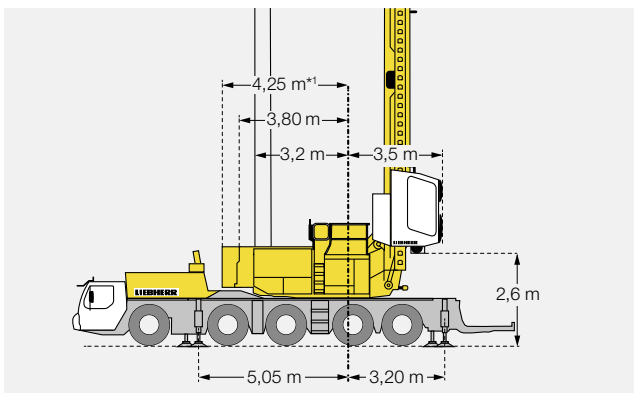
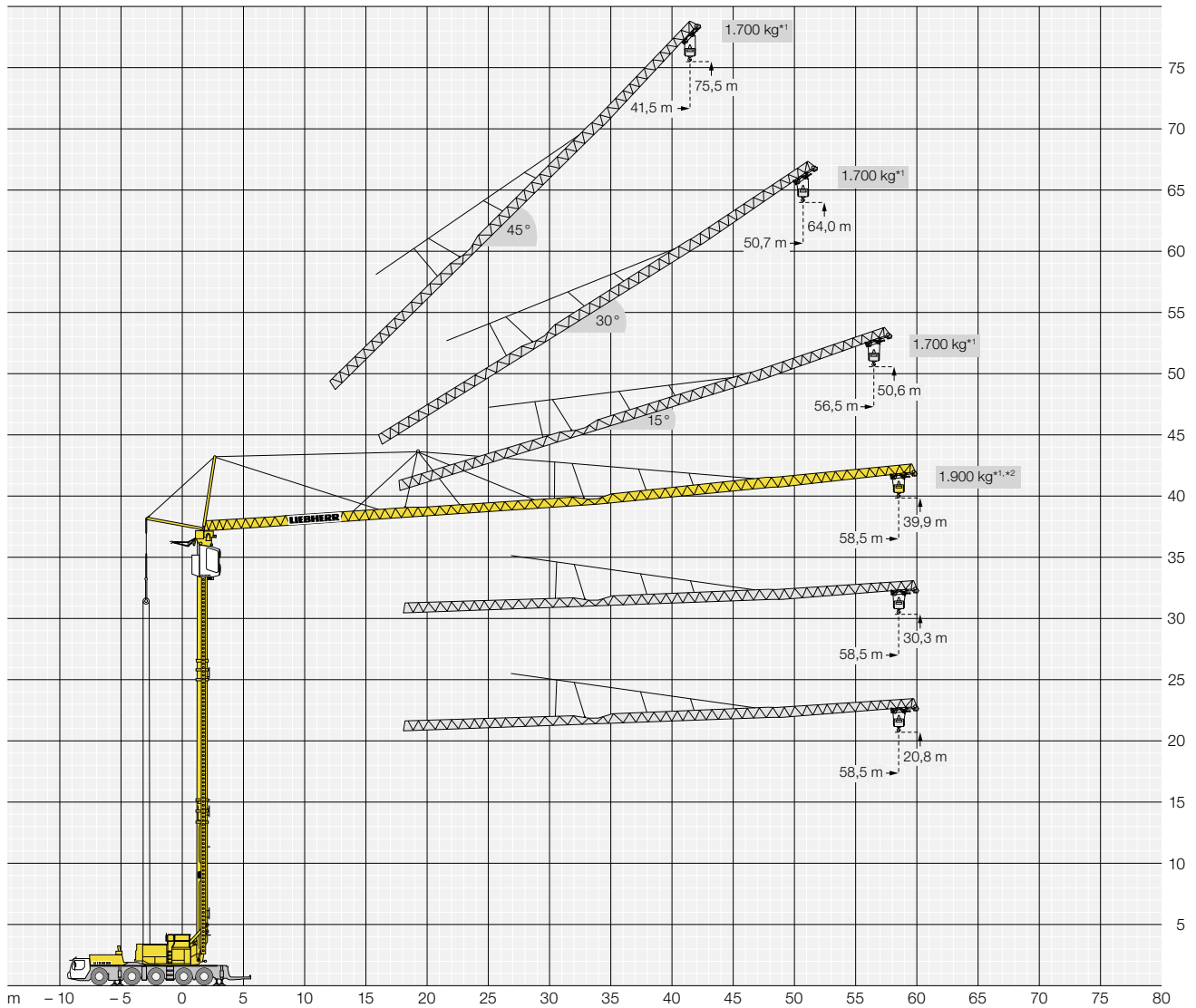

Plus load curves with control limitations in comparison to standard load curve. See the operating manual for more details.

Liebherr MK140

Erection procedure

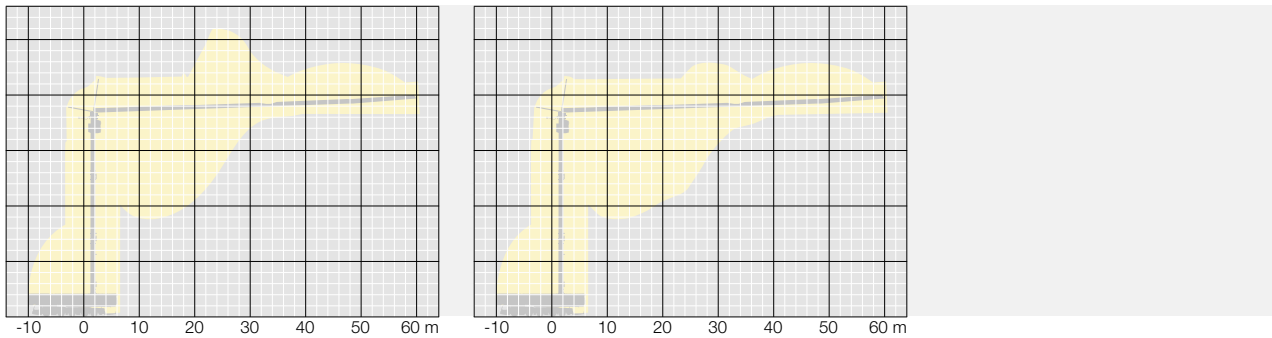

Transport

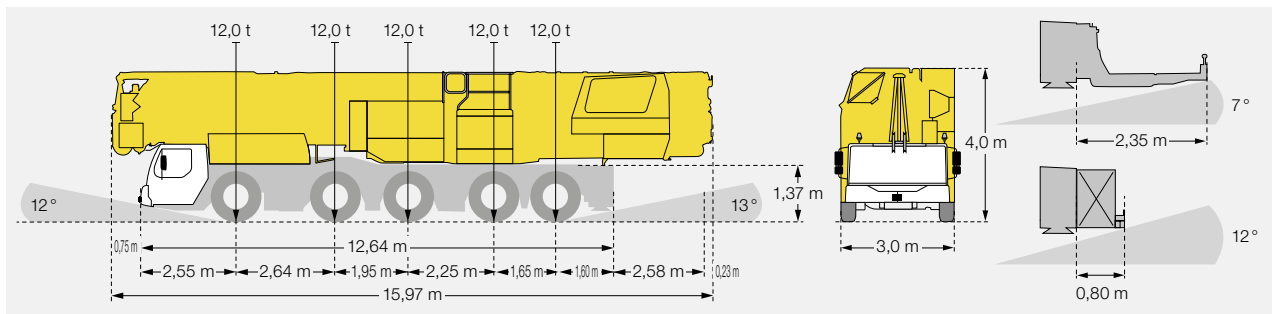

Plan view

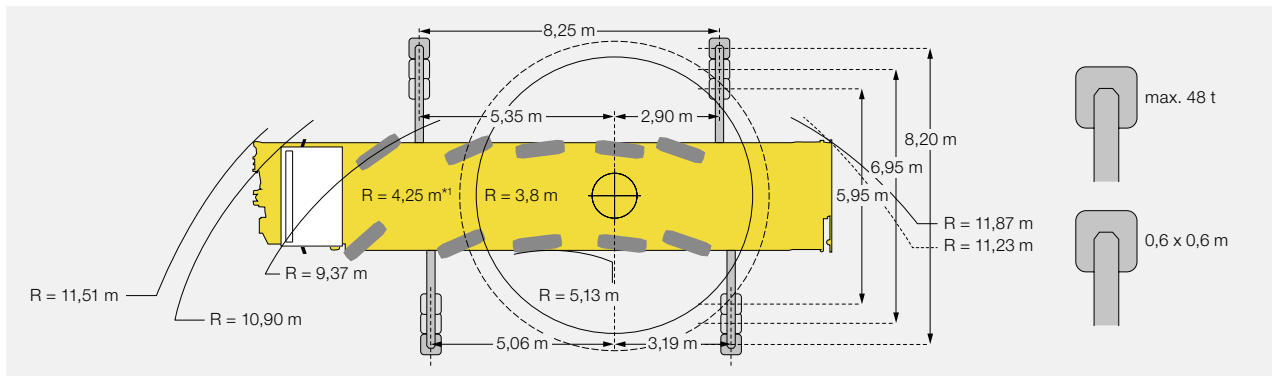

Weight

Transport weight: 60.000 kg
With additional ballast: 9.000 kg

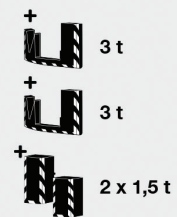

Remove additional ballast for road transport, observe country-specific regulations

Liebherr MK140

Luffing mode

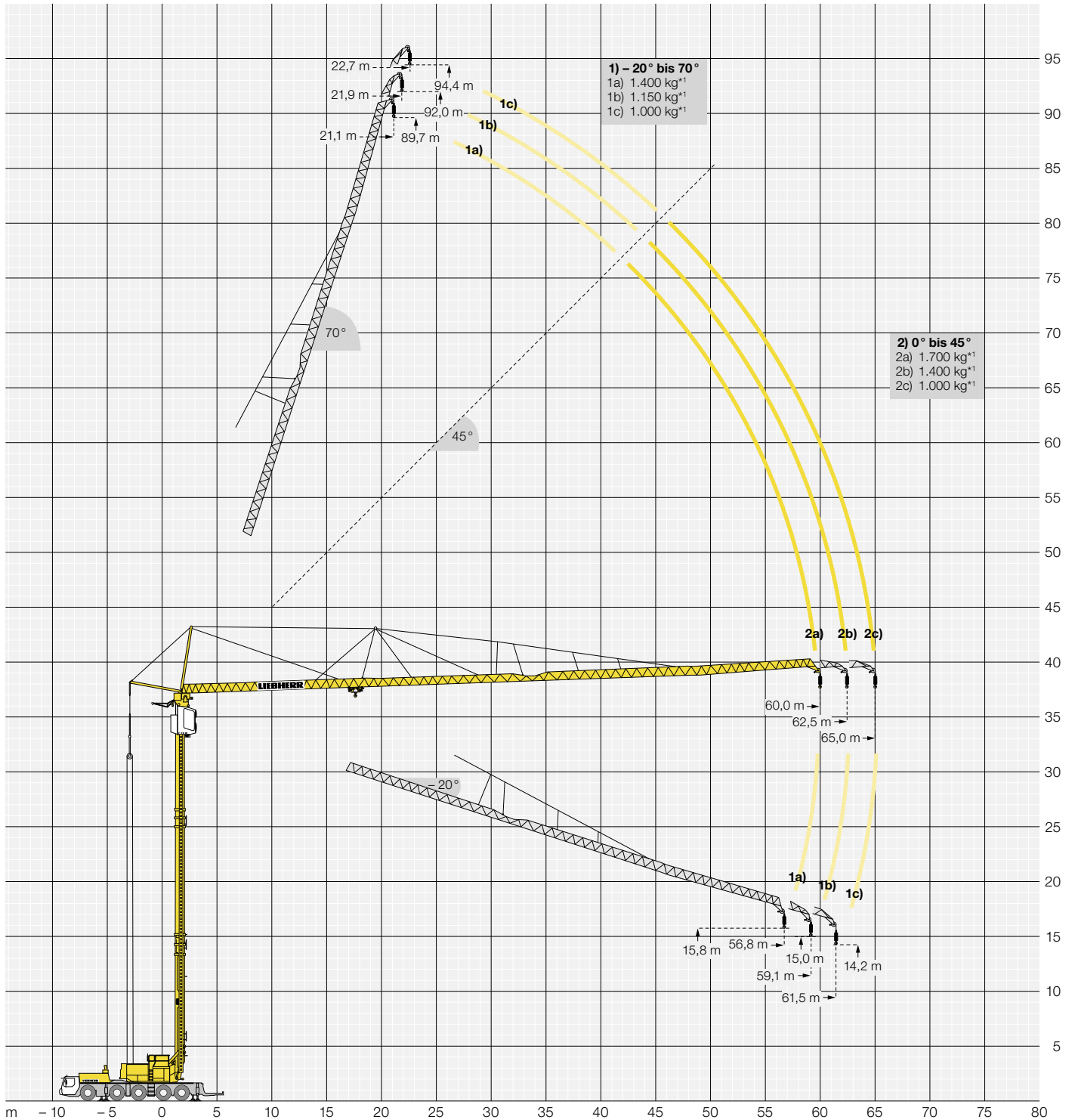

Load capacities with 9.0 t additional ballast

Liebherr MK140

Luffing mode



		70°	45°	0°	-20°
		21,1 m	43,0 m	60,0 m	56,8 m
		550	800	550	
+3 t		800	1150	800	
+6 t		1150	1400	1150	
+9 t		1400	1700	1400	

→ kg

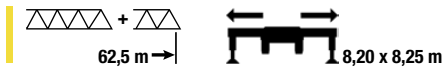

		70°	45°	0°	-20°
		21,9 m	44,7 m	62,5 m	59,1 m
		300	650	300	
+3 t		650	800	650	
+6 t		800	1150	800	
+9 t		1150	1400	1150	

→ kg

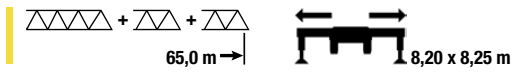

		70°	45°	0°	-20°
		22,7 m	46,5 m	65,0 m	61,5 m
			300		
+3 t			550		
+6 t			800		
+9 t			1000		

→ kg

Liebherr MK140

Trolley mode



				m																				
α°	m	m	kg	3,0	6,0	9,0	12,0	15,0	18,0	21,0	24,0	27,0	30,0	33,0	36,0	39,0	42,0	45,0	48,0	51,0	54,0	57,0	58,5	
0°	58,5		3,3 - 10,4	8000	8000		6780	5250	4260	3560	3050	2660	2340	2090	1880	1700	1550	1420	1300	1200	1110	1030	1000	
			3,3 - 8,1	8000	8000	7080	5100	3950	3200	2670	2280	1980	1740	1540	1380	1240	1120	1020	930	860	790	720	700	
15°	56,5		3,3 - 12,0	8000	8000			6080	4870	4040	3440	2980	2620	2330	2090	1880	1710	1570	1440	1320	1230	1140	1100	
			3,2 - 34,0	1800	1800										1670	1500	1360	1240	1130	1040	960	900		
30°	50,7		3,2 - 26,5	1800	1800						1750	1530	1340	1190	1060	950	860	780	710	640	600			
			3,0 - 12,0	6000	6000		4610	3720	3090	2630	2280	2000	1770	1590	1430	1290	1180	1080	1000					
45°	41,5		3,0 - 9,0	6000	6000	4280	3290	2640	2190	1860	1600	1390	1220	1080	970	870	780	710	650					
			2,7 - 31,0	1800	1800								1650	1460	1310	1200								
			2,7 - 25,0	1800	1800						1610	1390	1210	1060	940	850								

kg

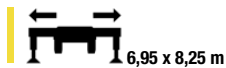

				m																			
α°	m	m	kg	3,0	6,0	9,0	12,0	15,0	18,0	21,0	24,0	27,0	30,0	33,0	36,0	39,0	42,0	45,0	48,0	51,0	54,0	57,0	58,5
0°	58,5		3,3 - 6,5	8000	8000	5430	3870	2970	2380	1970	1670	1430	1250	1100	970	870	770	700	630	570	510	470	450
			3,3 - 4,1	8000	8000	5180	3250	2320	1760	1390	1130	940	790	670	570	490	420	360	310	270	230	190	160
15°	56,5		3,2 - 20,0	1800	1800						1680	1410	1200	1030	900	790	690	610	540	480	430	380	350
			-	-	-																		
30°	50,7		3,0 - 7,0	6000	6000	4440	3150	2400	1910	1570	1320	1120	960	840	730	640	560	500	440	400			
			-	-	-																		
45°	41,5		2,7 - 19,0	1800	1800				1570	1300	1100	940	810	700	610	550							
			-	-	-																		

kg



No lifting capacity diagrams are available for this configuration.
The crane can be ballasted. See operating manual for more details.

Plus load curves with control limitations in comparison to standard load curve.
See the operating manual for more details.

= max. 14,0 m/sec (6,5 Bft) = max. 20,0 m/sec (8,0 Bft)

Liebherr MK140

Trolley mode

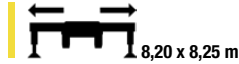
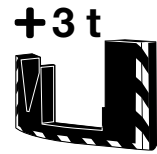

α°	m	kg	m																			
			3,0	6,0	9,0	12,0	15,0	18,0	21,0	24,0	27,0	30,0	33,0	36,0	39,0	42,0	45,0	48,0	51,0	54,0	57,0	58,5
0°	58,5		3,3 - 12,0	8000	8000		6240	5090	4280	3680	3220	2850	2550	2300	2080	1900	1750	1610	1490	1380	1290	1250
			3,3 - 9,85	8000	8000	6470	5070	4150	3500	3010	2630	2320	2070	1870	1690	1540	1410	1300	1200	1110	1030	1000
	Plus*2		3,3 - 13,5	8000	8000		7050	5690	4750	4060	3540	3130	2800	2530	2300	2100	1930	1790	1660	1540	1440	1400
15°	56,5		3,2 - 41,0	1800	1800										1740	1600	1480	1370	1270	1200		
			3,2 - 33,5	1800	1800										1640	1480	1350	1230	1130	1040	960	900
30°	50,7		3,0 - 14,0	6000	6000		5550	4510	3790	3250	2830	2500	2230	2000	1820	1650	1510	1390	1300			
			3,0 - 11,5	6000	6000	5710	4450	3610	3030	2590	2250	1980	1760	1580	1420	1290	1170	1080	1000			
45°	41,5		2,7 - 37,5	1800	1800										1700	1550						
			2,7 - 31,0	1800	1800										1650	1460	1310	1200				

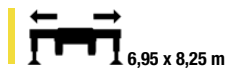

α°	m	kg	m																						
			3,0	6,0	9,0	12,0	15,0	18,0	21,0	24,0	27,0	30,0	33,0	36,0	39,0	42,0	45,0	48,0	51,0	54,0	57,0	58,5			
0°	58,5		3,3 - 8,35	8000	8000	7330	5260	4070	3290	2740	2330	2020	1770	1570	1400	1260	1140	1030	940	860	790	720	700		
			3,3 - 6,1	8000	8000	5200	3770	2920	2360	1960	1660	1430	1250	1100	970	870	780	700	630	570	520	470	450		
15°	56,5		3,2 - 27,5	1800	1800										1610	1420	1260	1130	1020	920	840	760	700	650	
			3,2 - 20,0	1800	1800										1680	1410	1200	1030	900	790	690	610	540	480	430
30°	50,7		3,0 - 9,5	6000	6000		4550	3490	2810	2330	1970	1700	1480	1300	1160	1030	930	840	760	700					
			3,0 - 6,5	6000	6000	4080	2900	2210	1760	1440	1200	1020	870	760	660	570	500	440	390	350					
45°	41,5		2,7 - 25,5	1800	1800										1660	1440	1260	1110	990	900					
			2,7 - 19,0	1800	1800										1570	1300	1100	940	810	700	610	550			



α°	m	kg	m																					
			3,0	6,0	9,0	12,0	15,0	18,0	21,0	24,0	27,0	30,0	33,0	36,0	39,0	42,0	45,0	48,0	51,0	54,0	57,0	58,5		
0°	58,5		3,3 - 5,0	8000	8000	6470	4040	2880	2200	1750	1440	1200	1020	870	760	660	580	500	440	390	340	300	260	250
			-	-																				
15°	56,5		-	-																				
			-	-																				
30°	50,7		-	-																				
			-	-																				
45°	41,5		2,7 - 16,0	1800	1800		1530	1240	1020	850	720	610	520	450	400									
			-	-																				

= max. 14,0 m/sec (6,5 Bft) = max. 20,0 m/sec (8,0 Bft)

Liebherr MK140

Trolley mode

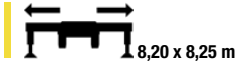
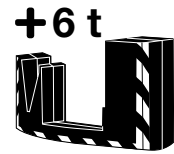

α°	m	kg	m																			
			3,0	6,0	9,0	12,0	15,0	18,0	21,0	24,0	27,0	30,0	33,0	36,0	39,0	42,0	45,0	48,0	51,0	54,0	57,0	58,5
0°	58,5		3,3 - 13,4	8000	8000		7110	5880	4990	4320	3800	3380	3040	2760	2520	2310	2130	1970	1830	1710	1600	1550
			3,3 - 11,5	8000	8000	7660	6090	5030	4270	3700	3250	2890	2590	2350	2140	1960	1800	1660	1540	1440	1340	1300
	Plus*2		3,3 - 14,4	8000	8000		7670	6340	5390	4680	4120	3670	3300	3000	2740	2510	2320	2150	2000	1870	1750	1700
15°	56,5		3,2 - 50,0	1800	1800												1750	1630	1550			
			3,2 - 42,0	1800	1800										1650	1530	1420	1320	1250			
30°	50,7		3,0 - 16,0	6000	6000		5280	4460	3840	3370	2990	2680	2420	2200	2010	1850	1710	1600				
			3,0 - 14,0	6000	6000		5550	4510	3790	3250	2830	2500	2230	2000	1820	1650	1510	1390	1300			
45°	41,5		2,7 - 39,0	1800	1800										1700							
			2,7 - 36,0	1800	1800										1620	1500						

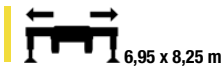

α°	m	kg	m																				
			3,0	6,0	9,0	12,0	15,0	18,0	21,0	24,0	27,0	30,0	33,0	36,0	39,0	42,0	45,0	48,0	51,0	54,0	57,0	58,5	
0°	58,5		3,3 - 10,5	8000	8000		6890	5380	4390	3690	3160	2760	2440	2180	1960	1780	1620	1480	1360	1260	1170	1080	1050
			3,3 - 8,35	8000	8000	7360	5360	4170	3390	2840	2430	2110	1850	1650	1470	1330	1200	1090	1000	920	840	780	750
15°	56,5		3,2 - 36,5	1800	1800										1650	1500	1370	1250	1150	1060	1000		
			3,2 - 28,5	1800	1800								1680	1490	1330	1200	1080	980	890	820	750	700	
30°	50,7		3,0 - 12,5	6000	6000		4870	3950	3300	2820	2450	2160	1920	1720	1560	1410	1290	1180	1100				
			3,0 - 9,5	6000	6000		4550	3490	2810	2330	1970	1700	1480	1300	1160	1030	930	840	760	700			
45°	41,5		2,7 - 33,5	1800	1800										1630	1470	1350						
			2,7 - 26,5	1800	1800								1750	1520	1330	1170	1040	950					



α°	m	kg	m																					
			3,0	6,0	9,0	12,0	15,0	18,0	21,0	24,0	27,0	30,0	33,0	36,0	39,0	42,0	45,0	48,0	51,0	54,0	57,0	58,5		
0°	58,5		3,3 - 7,1	8000	8000	6110	4400	3410	2750	2290	1940	1680	1470	1290	1150	1030	920	830	760	690	630	570	550	
			3,3 - 4,8	8000	8000	6340	4110	2990	2320	1860	1540	1300	1110	960	840	730	650	570	510	450	400	350	310	300
15°	56,5		3,2 - 23,5	1800	1800								1750	1500	1310	1150	1020	910	810	730	660	590	540	500
			-	-	-																			
30°	50,7		3,0 - 8,25	6000	6000	5440	3930	3040	2450	2040	1730	1490	1300	1140	1010	900	800	720	650	600				
			-	-	-																			
45°	41,5		2,7 - 23,5	1800	1800								1750	1490	1290	1130	990	880	800					
			2,7 - 16,0	1800	1800						1530	1240	1020	850	720	610	520	450	400					

= max. 20,0 m/sec (8,0 Bft)
 = max. 14,0 m/sec (6,5 Bft)

Liebherr MK140

Trolley mode

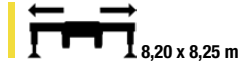
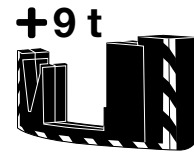

				m																				
α°	m	m	kg	3,0	6,0	9,0	12,0	15,0	18,0	21,0	24,0	27,0	30,0	33,0	36,0	39,0	42,0	45,0	48,0	51,0	54,0	57,0	58,5	
0°	58,5		3,3 - 13,4	8000	8000			7290	6220	5400	4750	4230	3790	3420	3110	2830	2600	2390	2200	2040	1890	1760	1700	
			3,3 - 12,0	8000	8000			6630	5630	4870	4270	3780	3380	3050	2760	2520	2310	2120	1950	1800	1670	1550	1500	
	Plus*2		3,3 - 14,4	8000	8000			7706	6504	5613	4925	4379	3934	3565	3254	2988	2758	2558	2381	2224	2084	1958	1900	
15°	56,5		3,2 - 54,0	1800	1800																			
			3,2 - 50,0	1800	1800																			
30°	50,7		3,0 - 16,0	6000	6000			5320	4540	3940	3480	3100	2790	2530	2310	2120	1960	1810	1700					
			3,0 - 14,0	6000	6000			5610	4680	4000	3490	3080	2740	2470	2240	2040	1880	1730	1600	1500				
45°	41,5		2,7 - 39,0	1800	1800																			
			2,7 - 36,0	1800	1800																			

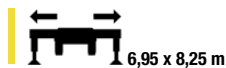

				m																				
α°	m	m	kg	3,0	6,0	9,0	12,0	15,0	18,0	21,0	24,0	27,0	30,0	33,0	36,0	39,0	42,0	45,0	48,0	51,0	54,0	57,0	58,5	
0°	58,5		3,3 - 12,7	8000	8000			6650	5430	4570	3930	3440	3050	2730	2460	2240	2040	1880	1730	1610	1490	1390	1350	
			3,3 - 10,5	8000	8000			6930	5440	4460	3760	3230	2830	2510	2240	2020	1840	1680	1540	1420	1310	1220	1130	1100
15°	56,5		3,2 - 44,0	1800	1800																			
			3,2 - 36,5	1800	1800																			
30°	50,7		3,0 - 15,0	6000	6000			4860	4070	3490	3040	2680	2390	2150	1950	1780	1630	1500	1400					
			3,0 - 12,0	6000	6000			4660	3780	3160	2700	2350	2070	1840	1650	1490	1350	1230	1130	1050				
45°	41,5		2,7 - 39,0	1800	1800																			
			2,7 - 33,5	1800	1800																			



				m																				
α°	m	m	kg	3,0	6,0	9,0	12,0	15,0	18,0	21,0	24,0	27,0	30,0	33,0	36,0	39,0	42,0	45,0	48,0	51,0	54,0	57,0	58,5	
0°	58,5		3,3 - 9,1	8000	8000			5890	4590	3730	3130	2680	2330	2050	1830	1640	1480	1340	1220	1120	1030	950	880	850
			3,3 - 6,8	8000	8000			5960	4390	3440	2800	2350	2010	1740	1530	1360	1210	1090	980	890	810	740	680	620
15°	56,5		3,2 - 31,0	1800	1800																			
			3,2 - 23,5	1800	1800																			
30°	50,7		3,0 - 10,5	6000	6000			5180	4040	3290	2760	2360	2050	1800	1600	1430	1290	1170	1060	970	900			
			3,0 - 7,75	6000	6000			5080	3680	2850	2300	1910	1610	1390	1210	1060	940	830	740	670	600	550		
45°	41,5		2,7 - 30,5	1800	1800																			
			2,7 - 23,5	1800	1800																			

= max. 20,0 m/sec (8,0 Bft)
 = max. 14,0 m/sec (6,5 Bft)

Liebherr MK140

In comparison to mobile cranes

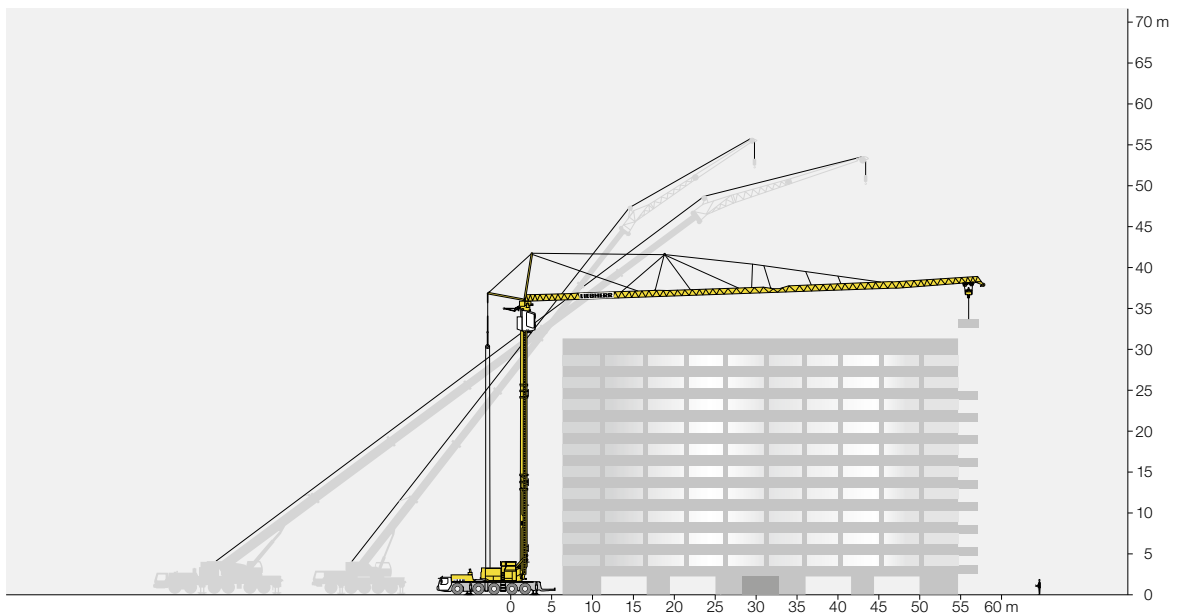
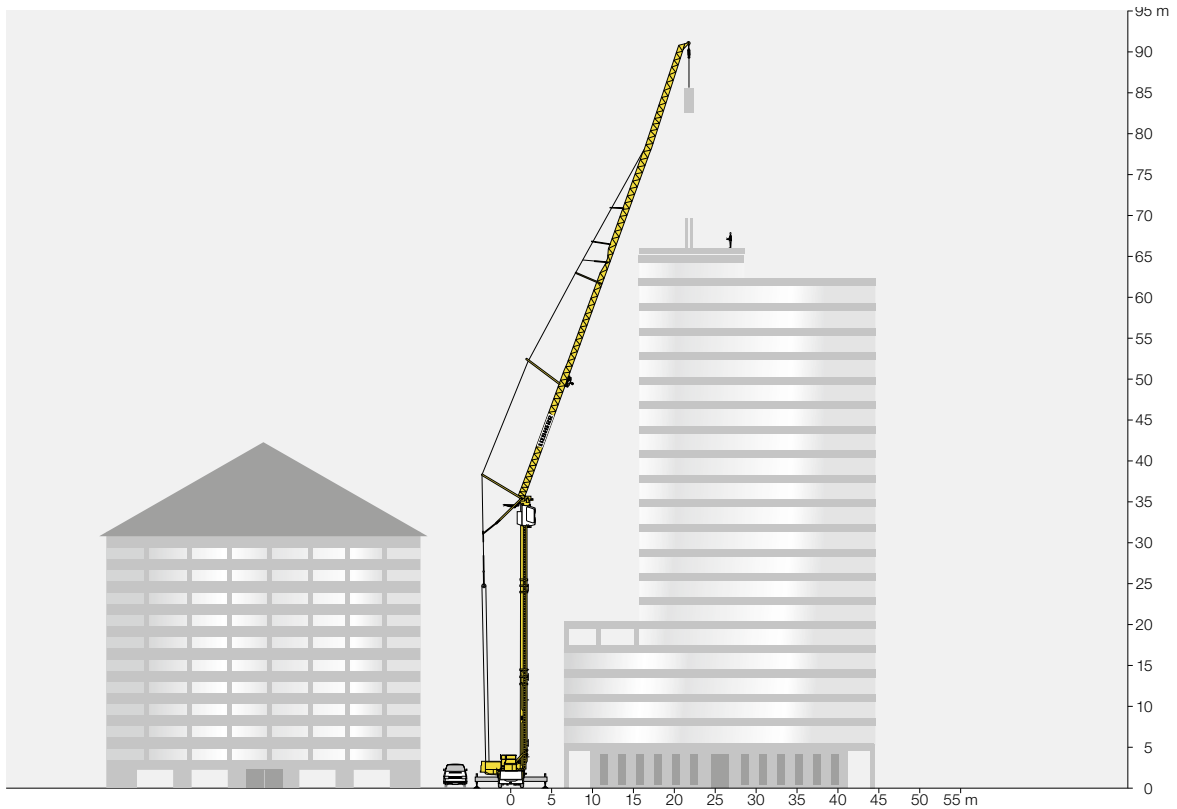

Southern Cranes & Access Ltd

Pollards Way, Southwater, Horsham, RH13 9AQ

Access hire: 01403 339105 . Crane hire: 01403 790874
sales@southerncranes.co.uk . www.southerncranes.co.uk

27 March 2017